

## Chapitre IV – Transformateurs triphasés

### Exercice 1 :

1/ le rapport de transformation

$$m = \frac{U_{20}}{U_1} = 0.02$$

2/

$$m = \frac{U_{20}}{U_1} = 0.02$$

$$U_1 = 4.44n_1fB_{\max}S$$

$$V_2 = 4.44n_2fB_{\max}S \Rightarrow U_{20} = \sqrt{3}4.44n_2fB_{\max}S$$

$$m = \frac{U_{20}}{U_1} = \frac{\sqrt{3}n_2}{n_1}$$

$$n_2 = 38 \text{ spires}$$

3/

$$P_{1cc} = 3rt_2I_{2cc}^2 \Rightarrow rt_2 = 12,8 \times 10^{-3} \Omega$$

4/

$$S_{2n} = \sqrt{3}U_{2n}I_{2n} \Rightarrow I_{2n} = 380 A$$

5/

a/

$$U_2 = U_{20} - (rt_2 \cos \varphi_2 - xt_2 \sin \varphi_2)I_2 \Rightarrow U_2 = 395.8V$$

b/

$$\eta = \frac{\sqrt{3}U_2I_2 \cos \varphi_2}{\sqrt{3}U_2I_2 \cos \varphi_2 + P_{fer} + 3rt_2I_2^2} = 97.5\%$$

**Exercice 2 :**

1/

$$m = \frac{U_{20}}{U_1} = 72,7 \times 10^{-3}$$

2/

$$V_1 = 4.44 n_1 f B_{\max} S$$

$$\Rightarrow U_1 = \sqrt{3} 4.44 n_1 f B_{\max} S$$

$$n_1 = \frac{U_1}{\sqrt{3} 4.44 f B_{\max} S} = 426 \text{ spires}$$

$$V_{20} = 4.44 n_2 f B_{\max} S$$

$$\Rightarrow U_{20} = \sqrt{3} 4.44 n_2 f B_{\max} S$$

$$n_{20} = \frac{U_{20}}{\sqrt{3} 4.44 f B_{\max} S} = 31 \text{ spires}$$

3/ schéma équivalent simplifié par phase à vide :

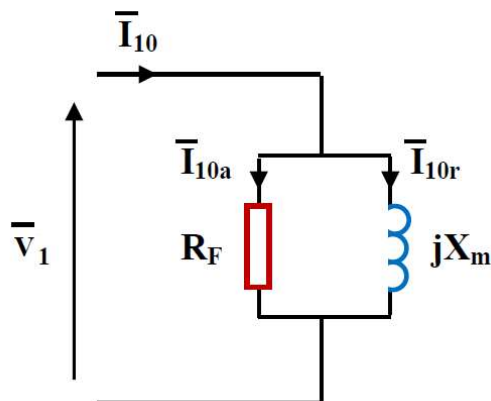

$$P_{10} = \frac{3V_1^2}{R_F} = \frac{U_1^2}{R_F} \Rightarrow R_F = 40.3 \text{ k}\Omega$$

$$Q_{10} = \frac{3V_1^2}{X_m} = \frac{U_1^2}{X_m} \Rightarrow X_m = 3,15 \text{ k}\Omega$$

4/

$$P_{1CC} = 3rt_2 I_{2CC}^2 \Rightarrow rt_2 = 41,3 \times 10^{-3} \Omega$$

$$xt_2 = \sqrt{\frac{m^2 V_{1CC}^2}{I_{2CC}^2} - rt_2^2} = \sqrt{\frac{m^2 U_{1CC}^2}{3I_{2CC}^2} - rt_2^2} = 73,1 \times 10^{-3} \Omega$$

5/

$$S_{2n} = \sqrt{3} U_{2n} I_{2n} \Rightarrow I_{2n} = 151,9 \text{ A}$$

6/

a/

$$U_2 = U_{20} - \sqrt{3}(rt_2 \cos \varphi_2 + xt_2 \sin \varphi_2) I_2 \Rightarrow U_2 = 380 \text{ V}$$

b/

$$\eta = \frac{\sqrt{3} U_2 I_2 \cos \varphi_2}{\sqrt{3} U_2 I_2 \cos \varphi_2 + P_{fer} + 3rt_2 I_2^2} = 95,7\%$$